

VIEW "1"

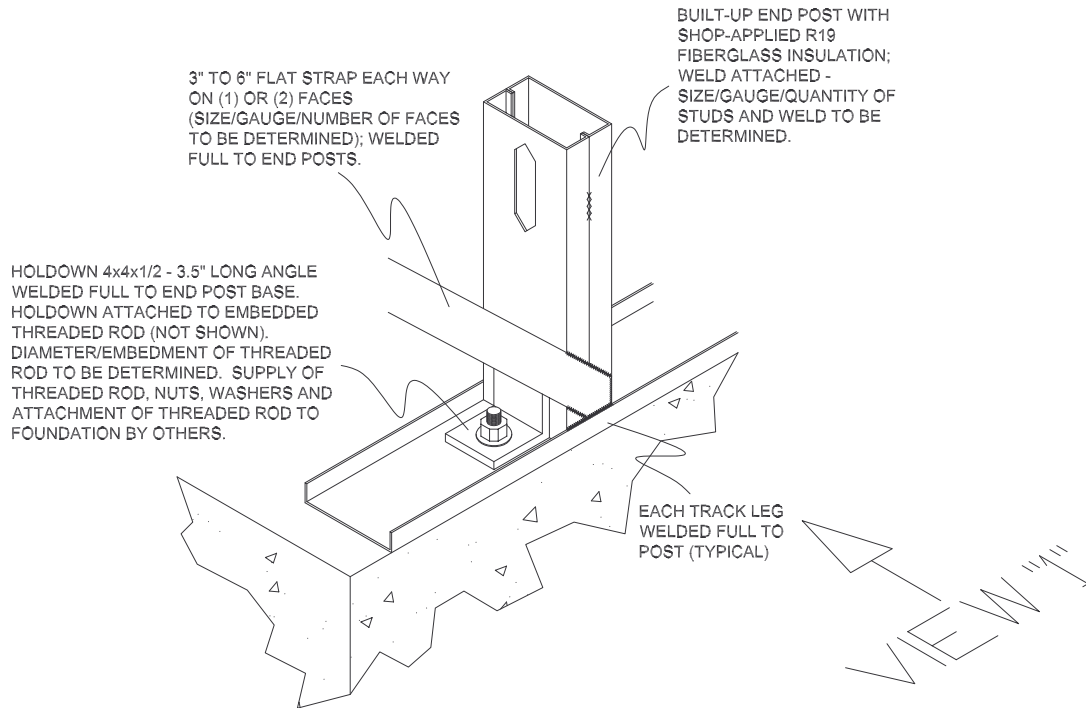

TYPICAL SHEAR-WALL
FOUNDATION CONDITION

!!! NOT FOR CONSTRUCTION !!!

Superior Truss & Panel
Incorporated

2204 West 159th Street
Markham, Illinois 60426-9998
Phone: (708) 339-1200 Fax: (708) 339-1248
Web Site: www.superior-truss.com



DRAWING: LG-12

Drawn By: M. Franklin
Scale: 1" = 1'-0"
Date: January 17, 2006

RELATED DRAWINGS:
LG-11
LG-13
LG-15