

PLAN VIEW OF PANEL-TO-PANEL CONNECTION
SCALE = 3" : 1'-0"

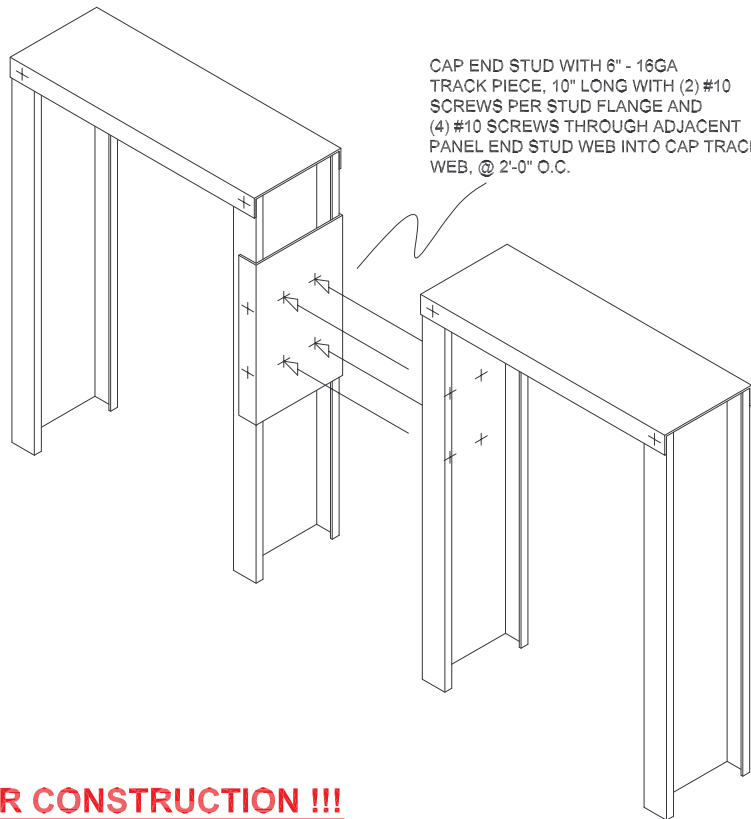

!!! NOT FOR CONSTRUCTION !!!

**TYPICAL OPEN-TO-CLOSED
END STUD PANEL CONNECTION
DETAIL**

Superior Truss & Panel
Incorporated

2204 West 159th Street
Markham, Illinois 60426-9998
Phone: (708) 339-1200 Fax: (708) 339-1248
Web Site: www.superior-truss.com



DRAWING: D1

Drawn By: M. Franklin
Scale: 1" : 1'-0"
Date: January 17, 2006