

TYPICAL INSIDE CORNER CONFIGURATION OF (3) FULL HEIGHT STUDS AT EACH CORNER INTERSECTION ATTACHED WITH #10 SDS - SIZE & GAUGE OF STUD TO BE DETERMINED. QUANTITY AND ON-CENTER SPACING OF SCREWS TO BE DETERMINED.

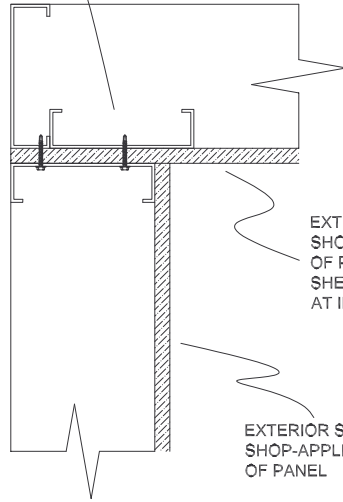

EXTERIOR SHEATHING SHOP-APPLIED TO FACE OF PANEL - NOTE THAT SHEATHING RUNS THRU AT INSIDE CORNERS

EXTERIOR SHEATHING SHOP-APPLIED TO FACE OF PANEL

TYPICAL INSIDE CORNER CONDITION

TYPICAL OUTSIDE CORNER CONFIGURATION OF (3) FULL HEIGHT STUDS AT EACH CORNER INTERSECTION ATTACHED WITH #10 SDS - SIZE & GAUGE OF STUD TO BE DETERMINED. QUANTITY AND ON-CENTER SPACING OF SCREWS TO BE DETERMINED.

EXTERIOR SHEATHING SHOP-APPLIED TO END OF PANEL

EXTERIOR SHEATHING SHOP-APPLIED TO FACE OF PANEL

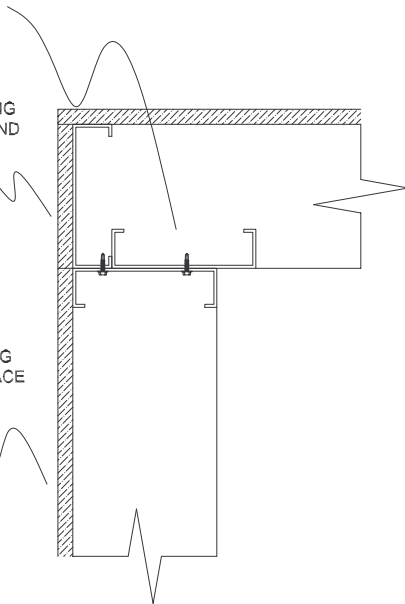

TYPICAL OUTSIDE CORNER CONDITION

!!! NOT FOR CONSTRUCTION !!!

Superior Truss & Panel
Incorporated

2204 West 159th Street
Markham, Illinois 60426-9998
Phone: (708) 339-1200 Fax: (708) 339-1248
Web Site: www.superior-truss.com

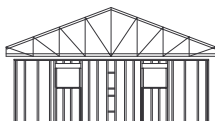

DRAWING: CORNER

Drawn By: M. Franklin
Scale: 1 1/2" : 1'-0"
Date: January 17, 2006